

These 8 1/4 inch diameter holes are .300 inch deep blind holes and they are optional.

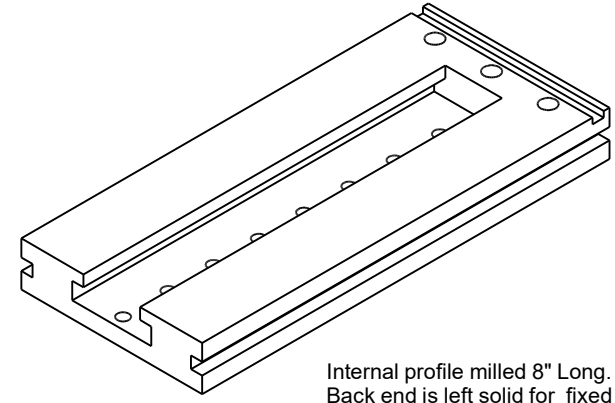

Internal profile milled 8" Long.
Back end is left solid for fixed jaw.

Accuracy of the vise will depend on the sliding fit between the sliding Jaw and this 1.250 slot.
Allow just enough clearance for a snug slide fit.

